



User's manual
Harness

 ACCESS
AIRBAG



SUP' AIR - VLD
34 rue Adrastée
Parc Altaïs
74650 Annecy - Chavanod
FRANCE

45°54.024'N / 06°04.725'E

www.supair.com



Thank you for choosing the ACCESS AIRBAG
We are glad to be able to share our common paragliding passion with you.

SUPAIR has been designing, producing and selling free flying equipment since 1984. By choosing a SUPAIR product you benefit from almost thirty years of expertise, innovation and listening. Our mission statement: research and develop to constantly enhance our product line.

We hope you will find this user's manual comprehensive, explicit and hopefully enjoyable as well. We advise you to read it carefully.

You will find the latest updated information about this product on our website www.supair.com. If you have further inquiries, feel free to ask one of our retailers for answers. And naturally, the entire SUPAIR team is at your disposal at info@supair.com

We wish you many safe enjoyable flying hours and happy landings.

Team SUPAIR

Introduction	4	In flight	23
Technical specifications.	5	Speed-bar use	23
Size choice	6	Landing	23
Components list	7	Using the reserve parachute	24
Equipment overview	8	Towing	24
Accessories assembly.	9	Mandatory thorough checkup.	24
Mini-bump	9	Maintenance	25
Seat-plate	10	Harness cleaning and maintenance	25
Speed-bar system	11	Storage and transport	25
Installing the reserve parachute.	12	Product longevity	25
POD reserve parachute handle connection.	12	Repairs	26
Reserve parachute/harness connection	12	Spare parts.	26
Reserve parachute characteristics	15	Materials	26
Installing the reserve parachute in its container	15	Recycling	26
Gear packing and tips.	17	Warranty	27
Adjustments	18	Disclaimer	27
The various adjustments	18	Pilot's gear	27
Adjusting the harness	19	Service Book	28
Wing/harness connection	20		
Inflight behavior	21		
Flight phases	22		
Pre-Flight check	22		
Takeoff	22		

Welcome to the paragliding world according to SUPAIR; a world of shared passion.
The ACCESS AIRBAG harness answers all the new pilot's requirements to safely progress. It was designed with schooling and fun in mind to provide full comfort and a worry free learning curve.

The harness ACCESS AIRBAG harness was certified EN 1651 : 1999 and LTF 91/09
Indicating that it meets European and German safety requirements.

After reading this manual we suggest you to check your harness during a hang-test to adjust it before your first flight.

N.B : Three important icons will help you when reading this manual



Advice



Caution !



Danger !!

Technical specifications

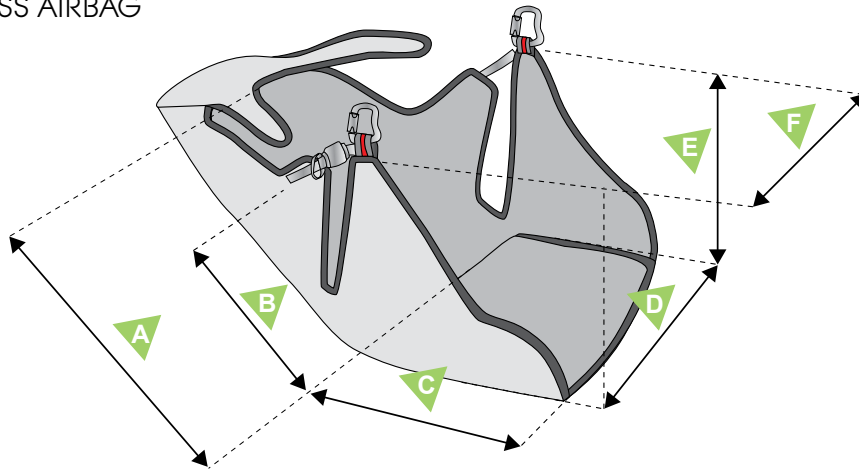

- A** Backrest height.
- B** Backrest tilt adjustments.
- C** Seat depth.
- D** Seat length
- E** Hooking point height.
- F** Length between the hooking points.

Model	XS	S	M	L	XL
Pilot size (cm)	155 - 170	160 - 175	170 - 185	180 - 195	190 - 205
Pilot weight (mini - maxi)	50 - 70 kg	55 - 80 kg	60 - 85 kg	70 - 95 kg	80 - 105 kg
Harness weight (+carabiners+speedbar)	4 260 g	4 310 g	4 360 g	4 670 g	4 730 g
Designed for	No				
Backrest height (cm) A	61	64	67	71	74
Backrest tilt adjustments (cm) B	36	40	44	45	46
Seat depth (cm) C	46	48	49	55	55
Seat width (cm) D	34	34	36	38	40
Hooking point height. (cm) E	45	45	45	45	45
Length between the hooking points. (cm) F	40-53	40-53	40-53	40-53	40-53
Impact damping system: Airbag	Yes				
Impact damping system: Bumpair	No				
Certification	Yes : EN 1651 : 1999 and LTF 91/09				
Tandem (Pilot or Passenger)	Passenger only				
Acrobatic flying	No				
Towing	Yes				
Reserve parachute pocket volume (Liters).	8.5 L				

Choosing your harness' size is important. You will find here below a height/weight table to help you with your size choice. With its hammock architecture and reclined flying posture, we advise you to try out the harness during a hang-test first at one of our retailers location to choose the correct size.

For a complete list of our retailers list click here : www.supair.com

Size Weight	1m55	1m60	1m65	1m70	1m75	1m80	1m85	1m90	1m95	2m
50		XS	XS							
55		XS								
60	XS	XS	S	S						
65	XS		S	S						
70		S	S		M	M				
75		S		M	M	M				
80			M	M	M		L	L		
85							L	L	L	
90						L	L	L		XL XL
95						L	L		XL	XL
100								XL	XL	XL

 Preliminary hang-test.

- 1 Harness
- 2 « B » reserve parachute handle. (réf. : POIB)
- 3 Zicral 45 mm carabiners. (réf. : MAILCOMOUS)
- 4 wood seat plate. (réf. : MPPL016 à MPPL020 selon la taille)
- 5 Mini-bump. (réf. : PROMINIBUMP)



Harness overview.

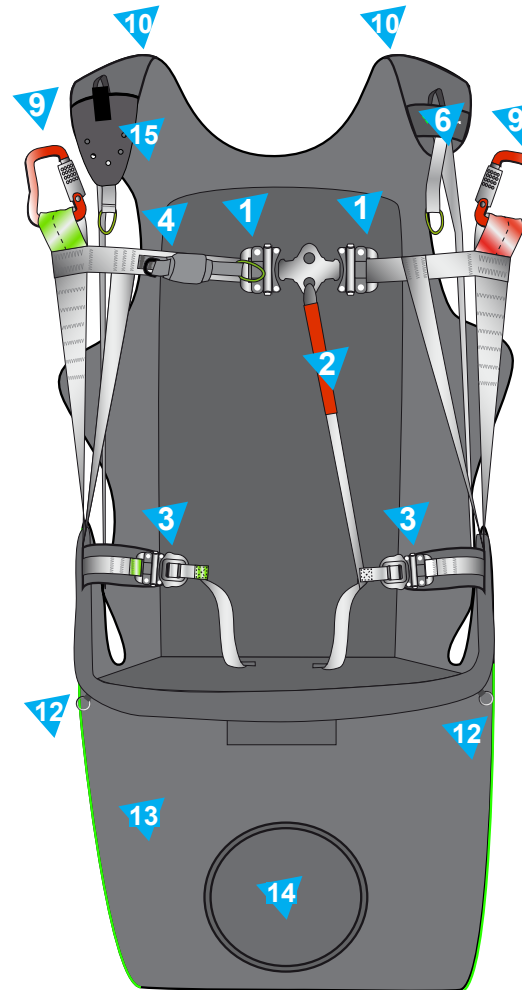

- 1 Chest strap with automatic buckles.
- 2 Safe-T-bar.
- 3 Leg strap buckle.
- 4 Chest strap adjustment.
- 5 Backrest tilt adjustment.
- 6 Shoulder straps adjustments.
- 7 Reserve parachute handle
- 8 Reserve parachute pocket.
- 9 Reserve paragliding main hooking points.
- 10 Reserve parachute hooking points.
- 11 Speed-bar/accelerator pulleys.
- 12 Speed-bar/accelerator rings.
- 13 AIRBAG
- 14 AIRBAG air intake.
- 15 Radio pocket.
- 16 Back storage pocket.
- 17 Small storage pocket.

How to install the Mini-bump.:

Ref. : PROMINIBUMP

1. Open the dorsal storage pocket.
2. Pull open the zipper found at the bottom of the dorsal storage pocket where the Mini-bump pocket access is located.
3. Insert the Mini-bump with its flat base first as indicated on the graphic.
4. Close the zipper.
5. Close the dorsal storage pocket.

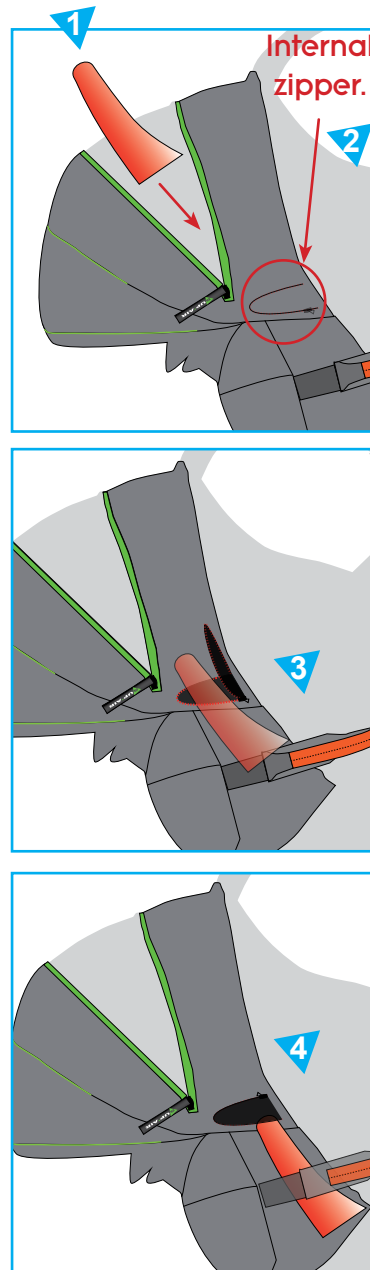

Profil view.

Top

Rear

Front

Bottom

Flight direction.

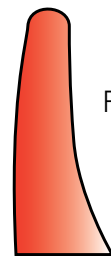

Accessories assembly. >> 1. Mini-bump



Accessories assembly.

>> 2. Wooden seat plate.

Seat plate description. :

Wooden seat plate.
Taille XS Ref. : MPPL016
Taille S Ref. : MPPL017
Taille M Ref. : MPPL018
Taille L Ref. : MPPL019
Taille XL Ref. : MPPL020

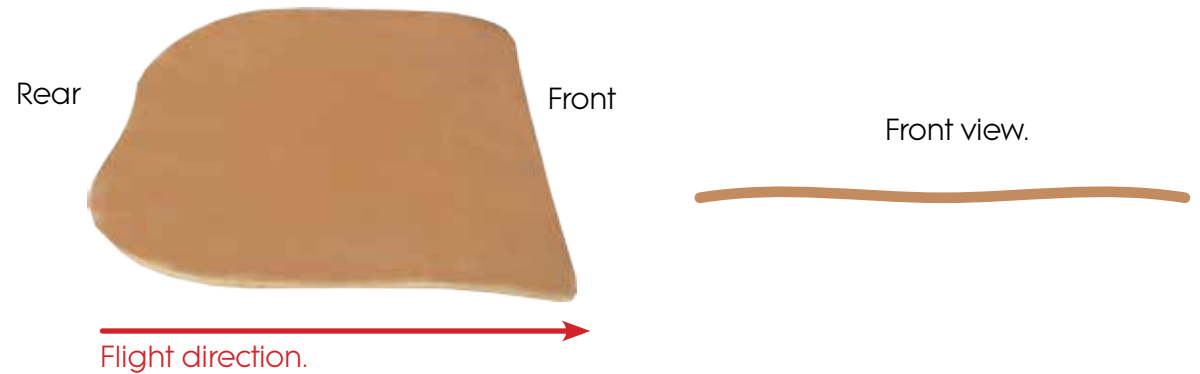

Installing the seat plate. :

1. Face the harness. Grab the upper layer end of the seating area and pull it toward you. Reach inside the seat-plate pocket and pull the leg straps rearward to give enough room to insert and sandwich the seat plate between them.
2. Sandwich the seat-plate between the leg straps and push it, leading edge first, all the way inside the seat-plate pocket.

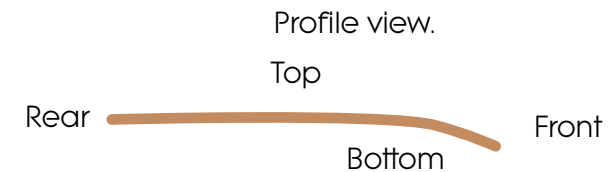

Accessories assembly.

>> 3. Speed-bar system.

Compatible accelerator/speed-bar :

STANDARD double stage speed-bar/accelerator.

Ref. : ACCELSOUPLE

Speedbar assembly. :

Regarding either side of the harness:

1. Push the accelerator cord through the ring located at the front of the seating area
2. Push the accelerator cord through the pulley located on the main strap.
3. Bring the cord back down and push it through the pulley connected to the side panel.
4. Finally, attach a hook to the cord before connecting it to the glider's speed-bar/accelerator.
5. Simulate the speed-bar/accelerator's functionality by sliding the cord back and forth.

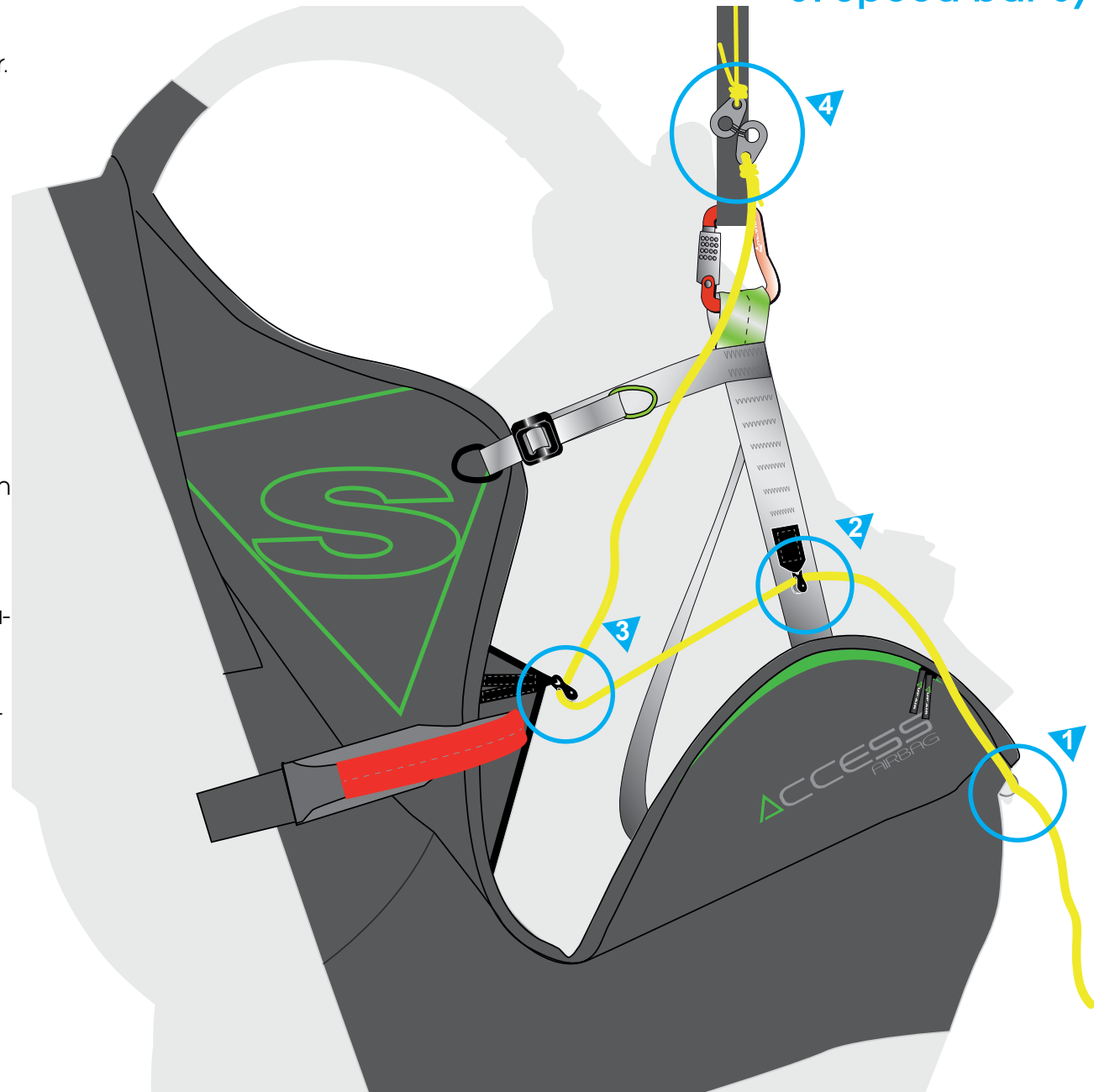

Installing the reserve parachute.



Thank you for reading the following carefully ! We recommend for the initial rescue parachute assembly and installation to be made by a qualified professional.

Reserve parachute folding and installation inside the harness must conform to the specific guidelines found in this manual.

- A** Reserve parachute handle (Ref. POIB).
- B** Reserve parachute inside its deployment bag and folded according the manufacturer's specifications.
- C** Parachute rigging lines
- D** Single reserve parachute handle.

Connecting the handle to the rescue parachute's deployment bag.

1. Fasten the handle strap to the POD's middle loop by making a loop to loop (Lark's head) knot.

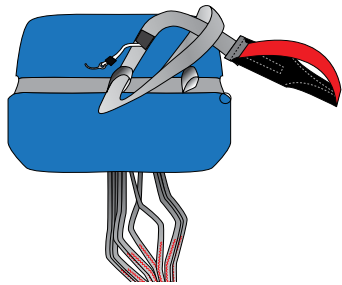

2. Tighten the handle/POD connection securely.

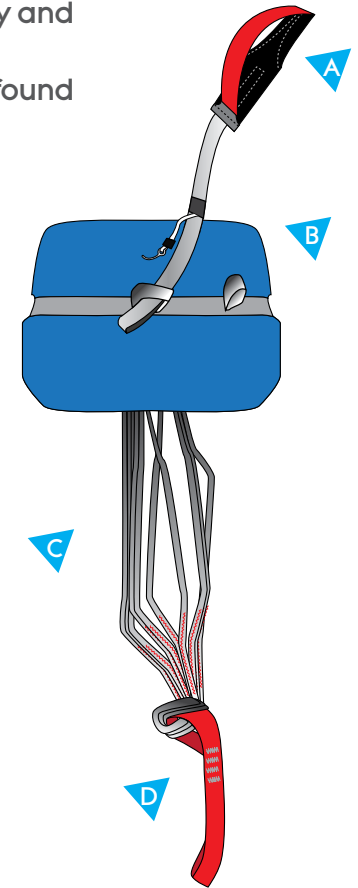
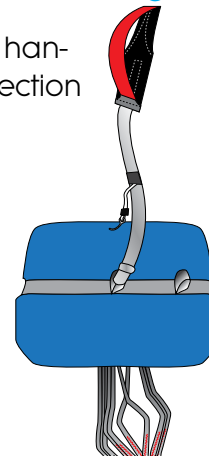

Reserve parachute/harness connection.

The reserve parachute installation will vary relative to the riser type used. Please review the following recommendations :

- « Y » risers setup (Ref.:ELESLOY).
 - >> Two (2) 6mm Maillons Rapides® are needed (Ref. : MAILCARIN6) + two (2) toric elastic rings (Ref. : MPPP044).
- Separate STD risers (Ref. : ELESLOSTD).
 - >> One (1) square 7mm Maillon Rapide® will be needed (Ref. : MAILCARIN7) + four (4) flexible toric rings (Ref. : MPPP044).

Follow the instructions corresponding to the type of risers you intend to use.

Installing the reserve parachute

Reserve parachute to harness connection with « Y » risers.

>> « Y » riser reserve parachute connection.

Make a loop to loop (Lark's head) knot between the single reserve parachute riser and the base of the « Y » riser where the bigger bridle diameter loop is located.

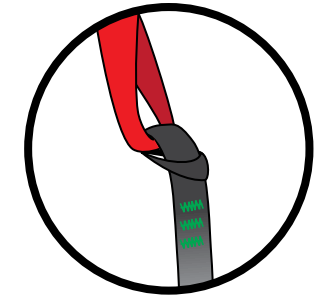

>> « Y » riser connection to the ACCESS AIRBAG harness.

1. - Take two (2) square 6mm Maillons Rapides® and two (2) flexible toric rings.
 - Unfasten the Velcros located alongside the shoulder protective sleeves to reach the reserve parachute connection loops on the shoulder straps.
2. - Open the Maillon Rapide®
 - Push the bridle's buckle through.
 - Push the maillon through the flexible toric ring.
 - Twist
3. - Push the riser's loop through the flexible toric ring.
 - Push the maillon through the riser's buckle.
4. - Give a second twist to the plastic ring.
 - Push the buckle through the maillon.
5. - Tidy up the assembly.
 - Be certain that the risers end loops are securely in place.
 - Close the maillon tightly by hand.
 - Complete tightening with pliers by making a tightening turn.

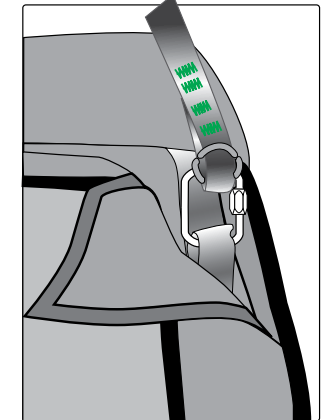
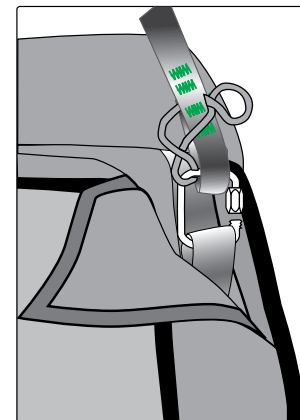
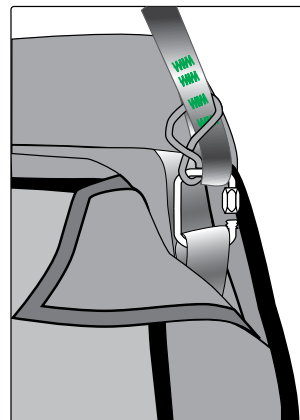
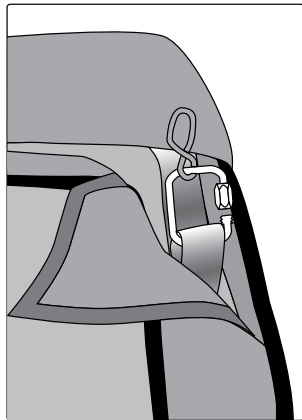

6. Repeat sequence 1 through 4 on the other side of the harness.

7. Tuck away the risers excess (without making knots) under one single flap :
 - Either to the right side if you wish to place your reserve parachute handle to the right (recommended if right handed).
 - Or to the left side if you wish to place your reserve parachute handle to the left (recommended if left handed).
 - Close the protective sleeves Velcros.

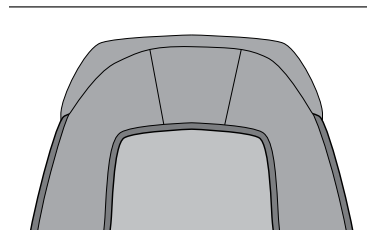
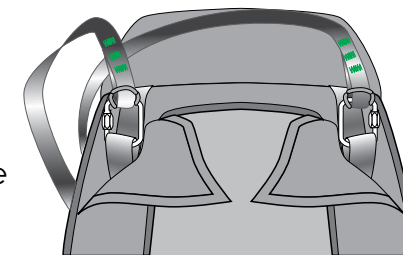

Installing the reserve parachute.

Reserve parachute/harness connection with separate risers.

>> Risers to ACCESS AIRBAG harness connection using a loop to loop (Lark's head) knot.

1. - Unfasten the Velcros located alongside the shoulder protective sleeves to reach the reserve parachute shoulder straps connection loops.

2. - Attach each riser to the shoulder attachment points by making a Lark's knot (loop to loop connection). Use the largest bridle loop ends.

3. - Assemble everything correctly.
- Make sure for the risers not to be longer than one another.
- Tighten each connection securely.

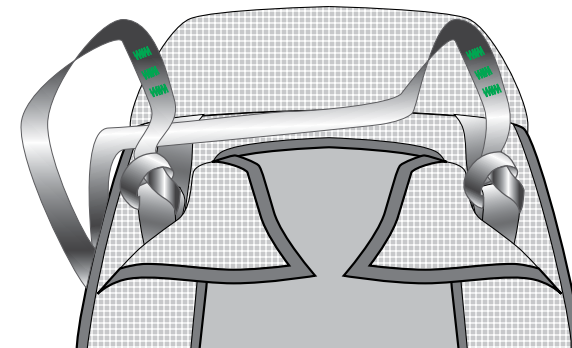
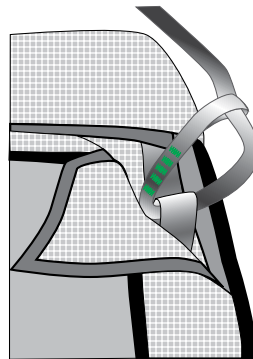
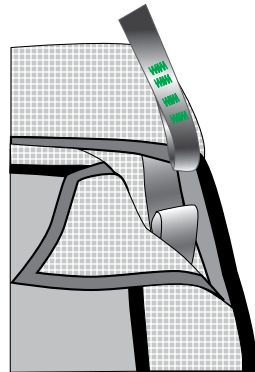

>> Separate riser reserve parachute connection.

One (1) square 7mm Maillon Rapide® will be needed + two (2) flexible toric rings.

1. - Open the 7mm square Maillon Rapide®.
- Connect the reserve parachute single riser loop.
- Push the maillon through the plastic ring
- Twist

2. - Push the end riser through the toric ring.
- Push the maillon through the risers buckles.

3. - Give a second twist to the plastic ring.
- Push the buckle through the maillon.

4. - Repeat steps 1 through 3 with the second riser.

5. - Tidy up the assembly.
- Be certain for the riser end loops to be securely fastened.
- Close the Maillon Rapide® tightly by hand.
- Tighten using pliers and making a turn.

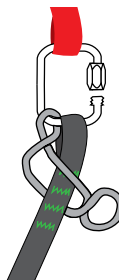
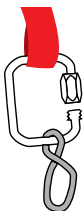

Reserve parachute parachute pocket characteristics. :

- Six (6) flap dorsal pocket.
- Locking via one (1) safety pin.
- Handle «B» (Ref.: POIB).
- 3 to 8,5 liters.

Adaptable to the SUP'AIR and other round reserve parachutes only (not the Rogallo type).

Possibility to position the reserve parachute handle to the right or to the left.

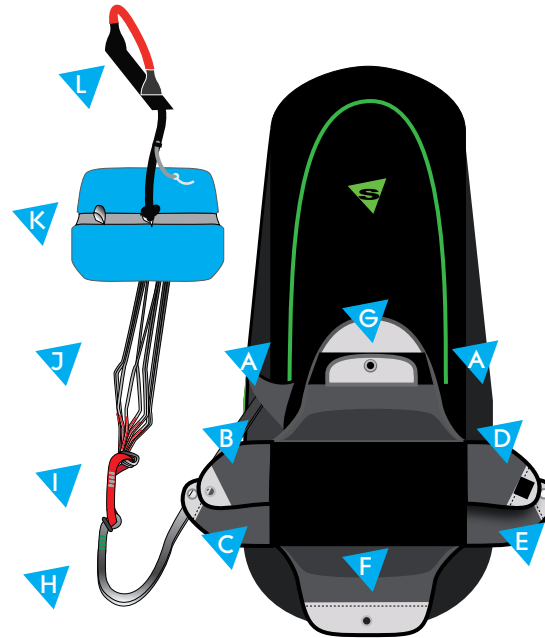

Installing the reserve parachute.

- A** Reserve riser protective sleeve.
- B** Left upper flap.
- C** Left lower flap.
- D** Right upper flap.
- E** Right lower flap.
- F** Lower flap.
- G** Upper flap.
- H** Reserve parachute risers.
- I** Reserve parachute single riser.
- J** Reserve parachute surplus lines (about 1 meter).
- K** Reserve parachute folded in its POD.
- L** « B » reserve parachute handle.

Installing the reserve parachute in its container.

1. - Place the risers « I » underneath the riser the protective sleeve « A » of the chosen side.
 - Then push them between flap « B » and the upper flap «G» to tuck away the risers and reserve parachute lines excess « J » to the bottom of the pocket.
 - Place the reserve parachute over them.
 - Pre-position the reserve parachute handle on the same risers side.
2. - Take a small piece of line to help with the installation procedure.
 - Push it through loop #1 (D marker).
 - Using the piece of line pull loop #1 through grommet #2 – flap (E)...
 - then inside grommet #3 – flap (B)
 - then inside grommet #4 – flap (C)

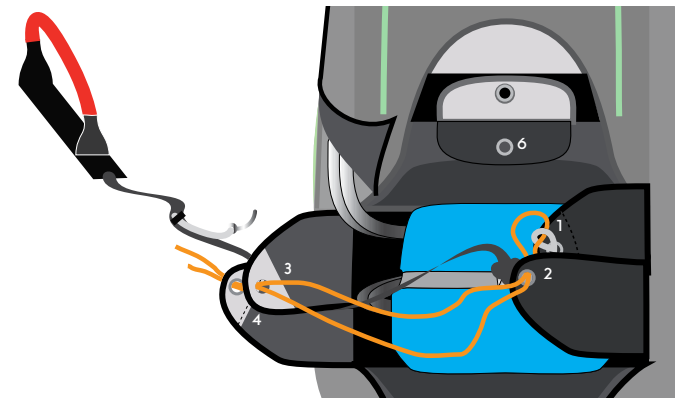
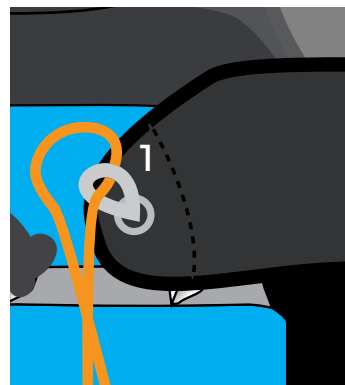
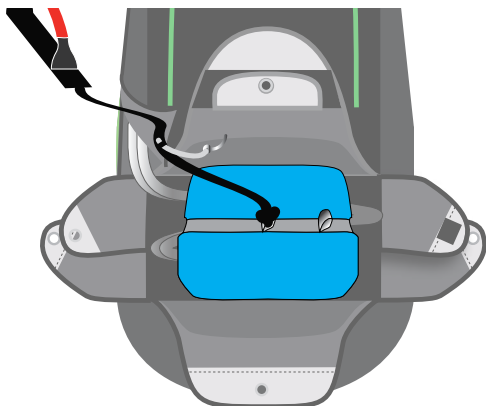

If your reserve parachute volume is too small, add the foam wedge to the end of the reserve parachute pocket (ask your dealer how to proceed if uncertain).

Reserve parachute installation (continued).

3. - ... then inside grommet #5 – flap (F)
- then inside grommet #6 – flap (G)
- Position the handle on the chosen side along the small strap following the lower flap.

4. - Secure the assembly by pushing the safety pin attached to the handle's strap trough loop #1.



Carefully remove the line.

- Tidy-up the installation and close the small flap.

5. - Fasten the handle to the Velcro on the chosen harness side (right or left).
- Close the riser protective sleeve « A » to finalize the installation.



Check the completed installation during a hang-test.

Have the installation checked by a professional outfit.
Conduct an extraction test every six (6) months to assure proper system functionality.

Note : conducting and extraction test does not imply deploying the reserve parachute which will stay inside its POD.

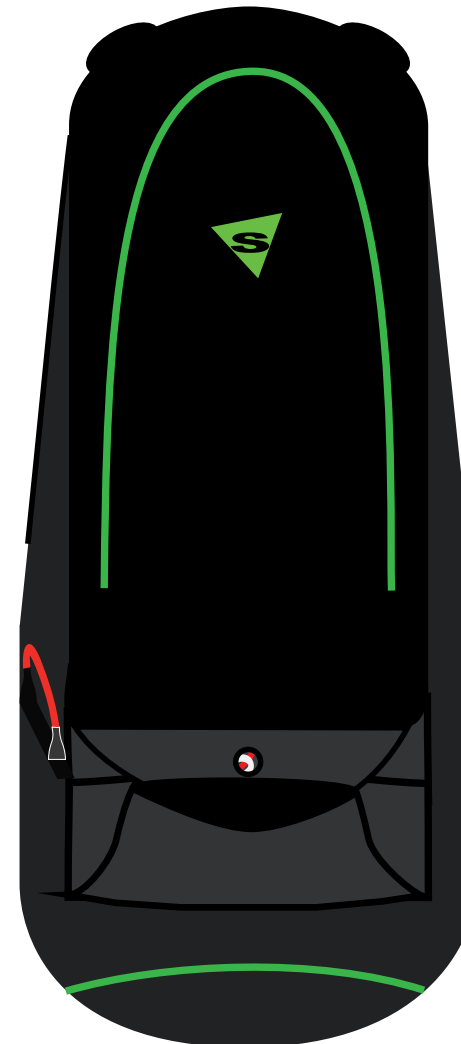
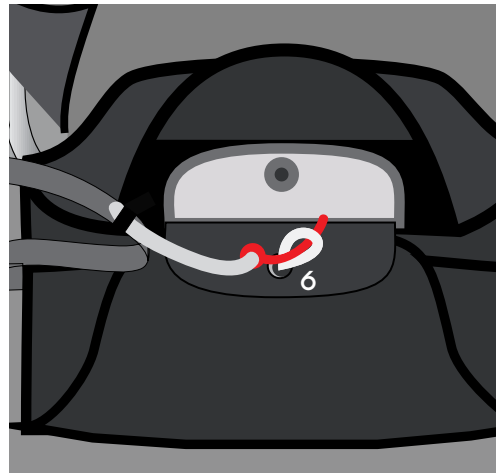
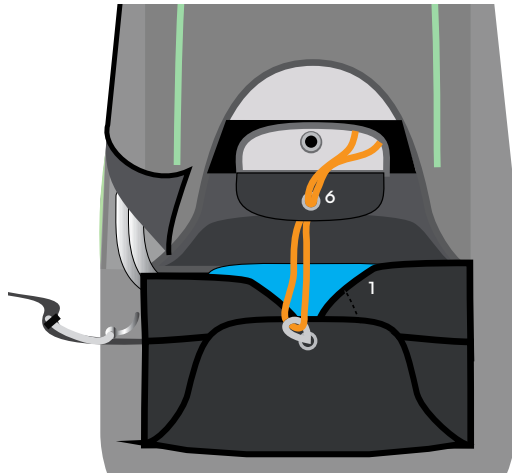

Gear packing and tips.



Tips : we have color coded the various locking buckles to help with the installation sequence and prevent beginner pilots from making mistake during harness fastening. It will also help the instructor to quickly spot any error made by the student during the pre-flight check procedure.

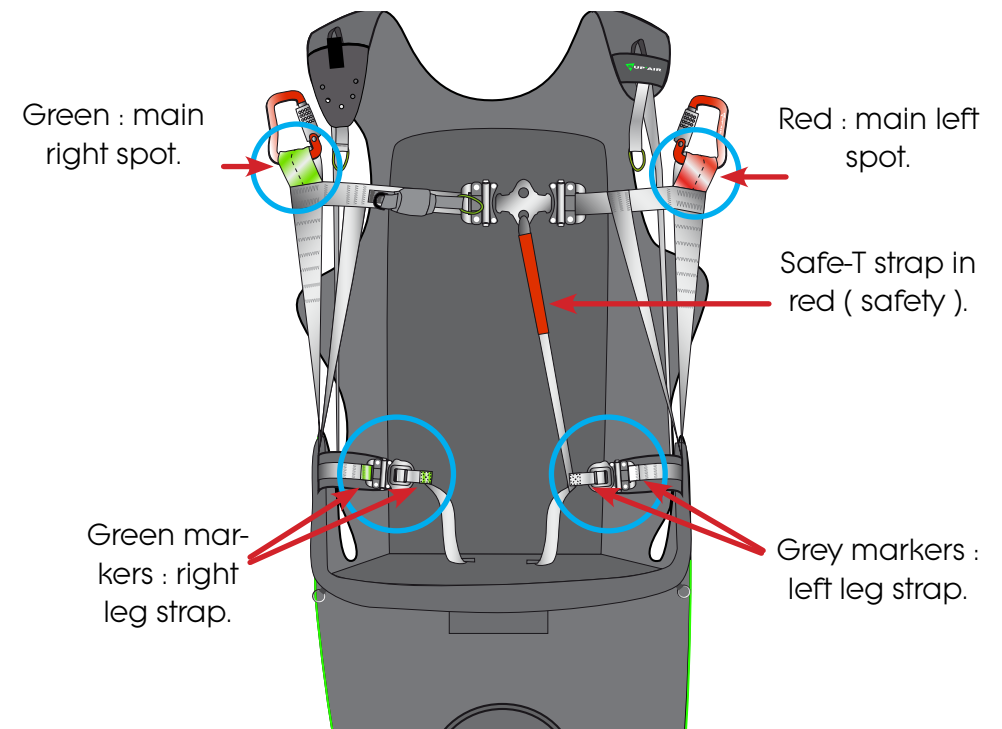

Tips: added markers on the straps help visualize and keep the ideal settings for each pilot.

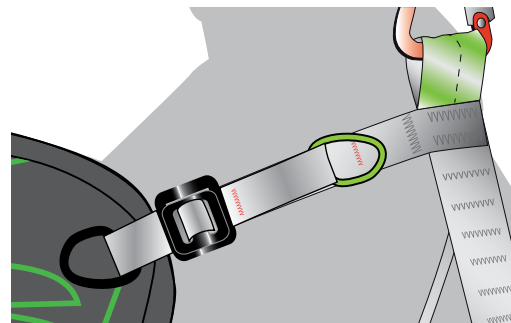

Adjusting the harness.



Adjusting the harness prior each takeoff is vital.

The various adjustments.

- 1 Adjusting the chest strap.
- 2 Adjusting the backrest.
- 3 Adjusting the shoulder straps.
- 4 Adjusting the leg straps.

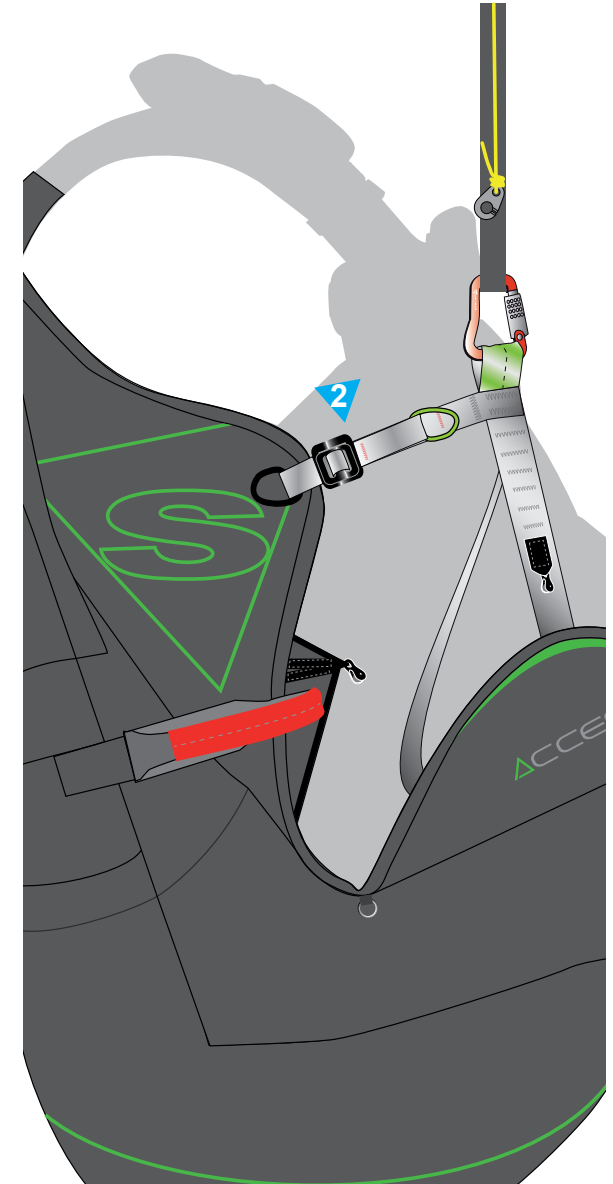
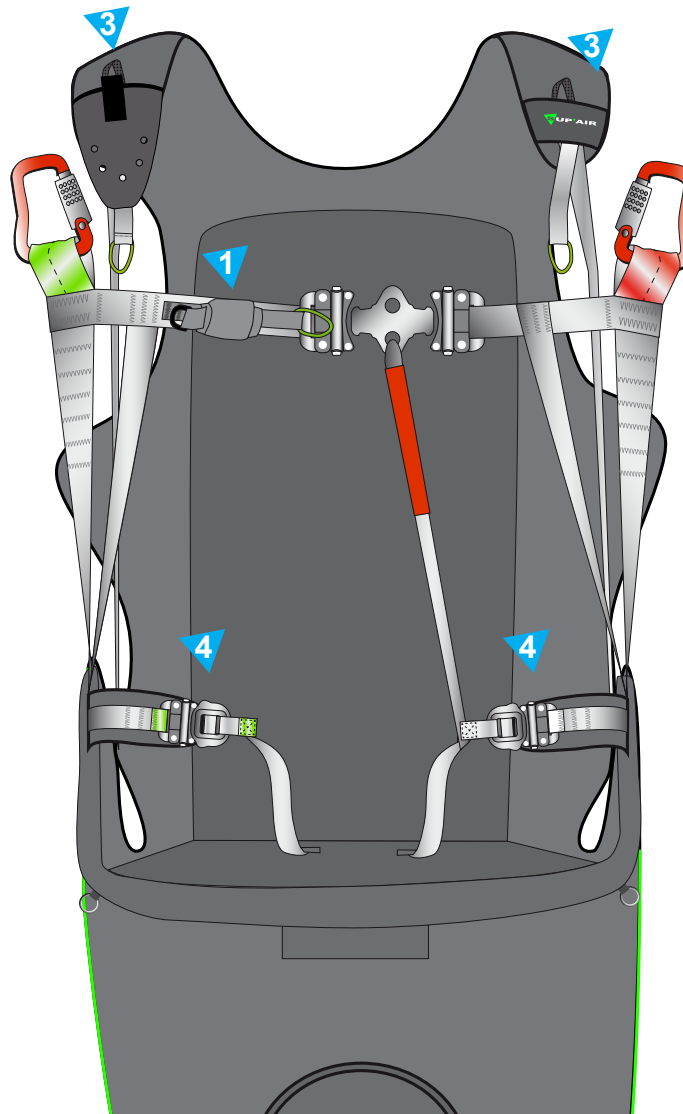

Harness adjustments.

Adjusting the harness.

1. Without strap tension, first adjust the backrest incline at the desired angle (red marker). Experienced under a hang-test device or in flight, this adjustment will be limited to the distance between the two red markers. Tightening will bring the backrest at a more vertical angle (recommended posture for beginners). Loosening the backrest will tilt the back support rearward.

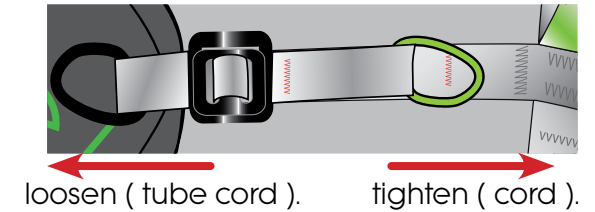

2. Seat inside the harness during a hang-test. Fasten the leg straps and chest straps self-locking buckles. Use the straps colored markers as guides if in doubt about the correct adjustments.

3. Adjusting the chest strap.



The distance to consider corresponds to the length between the middle points at the bottom of each carabiner.

The ideal distance varies between paragliding wing models. Adjust your harness's chest strap according to the wing manufacturer's recommendations. On average, this distance varies from 40cm to 45 cm.

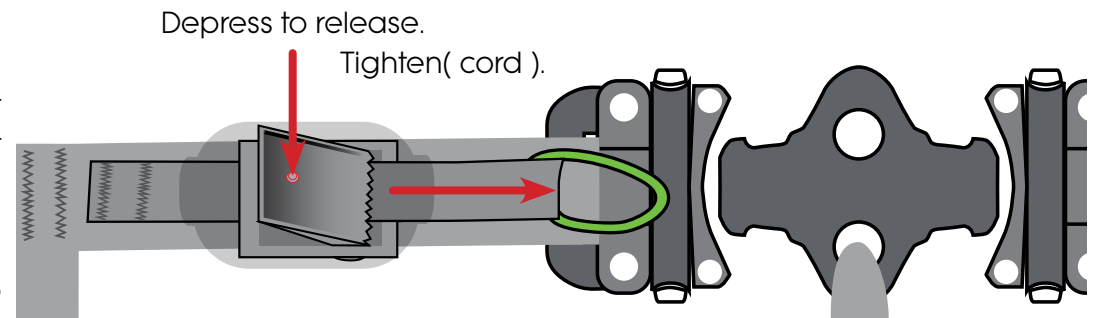

4. Adjust the shoulder straps length using the trimmers.



The pressure on the shoulder straps contributes to general comfort in flight. It must be precise: not too tight nor too loose. The upper area of the straps must offer enough support to maintain your torso in a comfortable position.

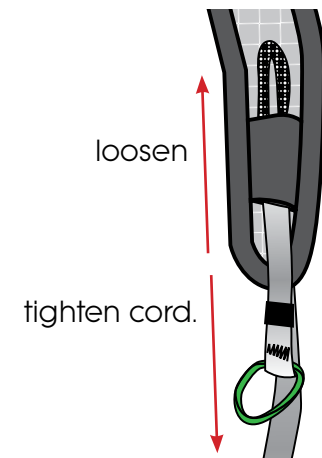

Connecting the wing to the harness.

Connecting the wing to the harness.

Without twisting the risers, connect them to the harness attachment loops using the self-locking carabiners.
Check for the risers to be properly positioned and untwisted. The «A» risers must be located at the front and facing the flight direction (see diagram).
Lastly, check for the main self-locking carabiners to be fully closed and locked in place.

Tips : as found on each ENOA wing, the attachment points to the harness are similarly identified with the following color coded markers : right in green and left in red.

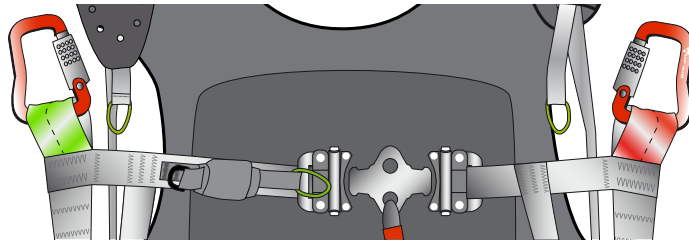

Installing the accelerator.

Install the accelerator by following the previous instructions.
Connect it to the wing using the split hooks.
Once the accelerator/speedbar is connected adjust its length according to the wing recommended measurements.
For correct use there must not be **any line tension at the split hook level when the accelerator/speedbar line is fully relaxed.**

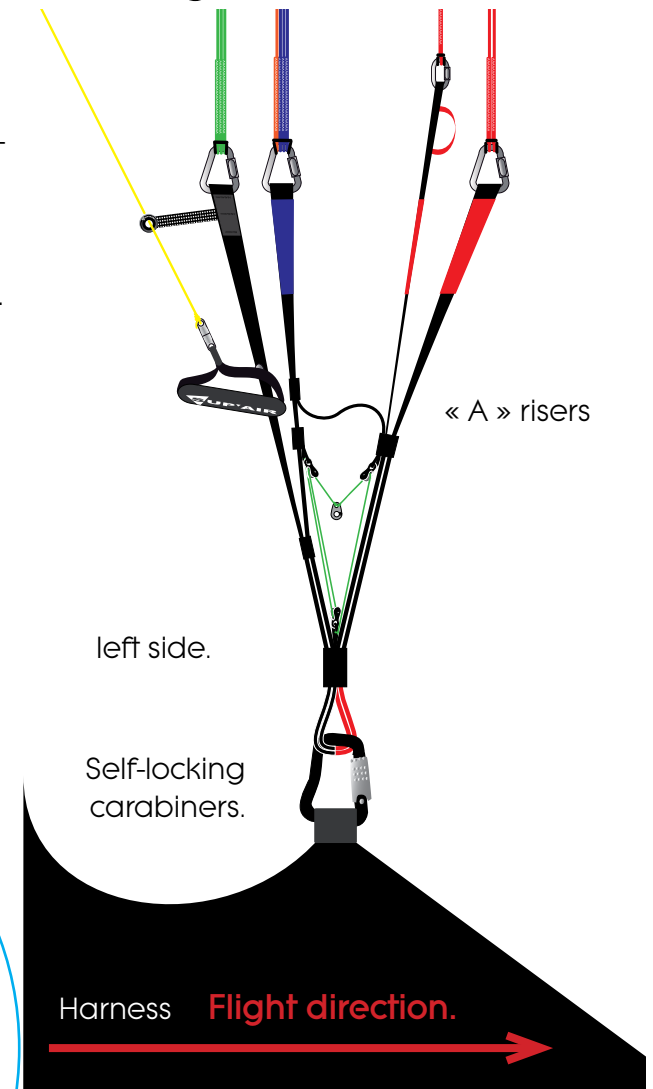
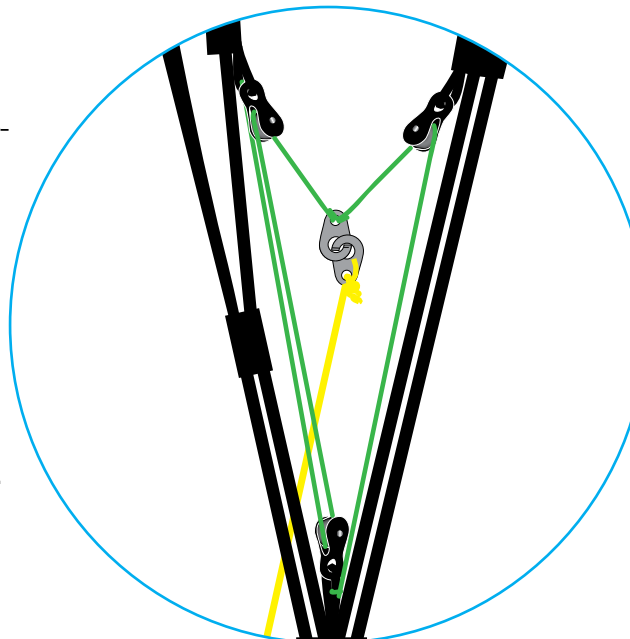



Flight behavior.

The ACCESS AIRBAG is a stable and comfortable harness providing an easy running to seating transition due to its design and padded protections. It is an ideal harness for ground handling and learning how to fly.

The ACCESS AIRBAG was designed with great passive/active safety levels in mind to help new pilots during their progression (upright posture, easy running and transition phase to seating).

To discover your new harness, we will recommend making your first flights on a school training hill in calm weather conditions with low wind speeds.

Pre-Flight control.



- Inspect the harness and the carabiners for possible wear and tear.
- Be certain for the reserve parachute safety pin to run through the reserve parachute pocket's flaps holding loop.
- Check that your personal settings haven't changed.
- Check that all zippers and buckles are closed.
- Check that the speedbar is correctly connected and adjusted.
- Check that no rigging line or other object comes in contact and interfere with the rescue parachute handle.
- Make sure that the self-locking carabiners are locked and connected to the paraglider.
- Check that the line of the speed system don't run through the rescue handle.

Takeoff



After a thorough weather conditions analysis was conducted and the decision to fly was made, put your harness on and follow the next steps :

- Fully close the leg straps, Safe-T-bar and chest strap buckles..



- Takeoff maintaining a vertical posture and push yourself inside the harness but only once away from the ridge.



Do not let go the brakes when close to terrain.

In flight.



Once in flight, the ACCESS AIRBAG harness becomes very instinctive to use and stable.

Set the distance between the two carabiners according to the aerology of the moment, and the wing manufacturer's recommendations.



Tightening the chest-strap provides more stability but less piloting efficiency while increasing the risk of riser twisting.

On the contrary loosening the strap provides more efficiency but can be dangerous in turbulent aerology (increased risk of falling towards the collapsed side of your glider).

Speedbar use.

We recommend using the speed-bar cautiously due to the increased risk of a partial or full frontal collapses.



Use the speed-bar/accelerator (transitions) only when far away from the ridge and in calm weather conditions as the wing becomes more sensitive to turbulence when accelerated. If you feel a loss of tension in the speed-bar/accelerator, stop pushing it and apply a light brake pressure on the toggles to prevent the glider from experiencing a potential frontal collapse.



Beware not to push on the speed-bar/accelerator to enter the harness after takeoff (it is not a foot-rest) or there could be the risk of a frontal collapse taking place as a result.



To use the speed-bar/accelerator, backpedal and grab the bar with the back of your shoe, push and use the second foot to stabilize it or to grab the second bar.

Apply pressure symmetrically to the first stage (first bar), when reaching the maximum enabled distance then push on the second stage (upper bar). To decelerate, reverse the procedure.

Landing



Always be certain to have enough altitude to make a landing approach corresponding to the weather conditions of the moment and terrain. During the landing approach, never make hasty maneuvers. Always land upwind in a standing posture and be ready to run upon touchdown if necessary.

During your final approach, use as much airspeed as possible based on the weather conditions of the moment, then gradually reduce the glider air speed by pushing the toggles all the way down until contact with the ground is made. Beware not to brake too soon and too rapidly and too deep which could lead to a stall and a dangerous landing.

During high wind speed landings, turnaround and face the wing as soon as ground contact is made and move toward the wing while braking symmetrically to deflate it.

Do not land in a seated position as it is dangerous.

Using the reserve parachute.

Throwing the reserve parachute.



It is strongly recommended to frequently check your reserve parachute handle location while in flight. This exercise should be executed instinctively and will increase your chances of a successful parachute extraction in case of an emergency.

Estimate your AGL (Altitude Above Ground Level) which if high enough may make it worth trying to bring your wing back to a normal flying configuration. If in doubt quickly deploy your emergency parachute.

Deploying a rescue parachute should only be done in an emergency.



With a strong lateral and then vertical tug, pull the handle towards you and then throw the parachute away from you (including the container and its handle) toward a clear unobstructed area of the sky. As soon as the parachute deploys, bring as much of the glider as possible toward you by pulling symmetrically on the "C" or "D" risers or on the toggles/brakes.

Be prepared to land by adopting an upright position with knees together and legs slightly bent. Prepare to roll down, hands on your chest, ankles together with pivoting hips and shoulders in a Paragliding Landing Fall (PLF) configuration.

Towing

To takeoff under tow you must be equipped with a quick release specially designed for the task.

Connect the towing release system to the main carabiner attachment points in accordance to manufacturer recommendations.

Before towing you should consult with a competent towing outfit about safety recommendations.

Mandatory controls.

Mandatory biannual inspection.



- Ascertain parachute deployment functionality by pulling the handle to activate a clean POD extraction sequence.
- Inspect the harness for wear and tear.

Annual check



- An annual deployment and repacking of the reserve parachute must be conducted by competent and certified personnel.

Harness cleaning and maintenance.

It is a good idea to clean your harness from time to time. We recommend using a brush and soft solvents only (soap or mild cleaning agents).

Rinse thoroughly. Never use aggressive chemicals such as strong solvents which could be harmful to the fabric, webbings, stitching and weaken the overall integrity of the harness.

The zippers should be lubricated from time to time using a silicon spray.

If you regularly use your harness in a dusty environment (dirt sand etc...) we advise you to regularly check and maintain your carabiners and buckles : clean them with a mild detergent then blow-dry them fully but **DO NOT LUBRICATE !**

Prior to using them conduct a thorough carabiners and buckles checkup to insure their full functionality.

If you use your harness in a marine/sandy/salty environment pay particular attention to your gear and follow a regular rigorous maintenance routine.

Storage and transport.

When not in use your harness should be stored inside your paragliding backpack in a dry cool and clean place protected from UV exposure. If your harness is wet please dry it thoroughly before stowing it away.

During transport protect the harness against mechanical or UV deterioration (use a bag). Avoid long transports in wet conditions.

Life-span



Once every two (2) years a thorough harness inspection must be conducted :

- Webbing wear and tear (no excessive wear nor rip beginning or unwanted folds).
- Buckles and carabiners (functionality wear and tear).
- The AIRBAG's integrity (especially after a strong impact), in other words, no holes, tears or rips.



The threads and fabric used to manufacture the ACCESS AIRBAG were specifically selected for their quality and resilience capacities. However in particular instances such as long term UV exposure abrasion, contact with damaging chemicals, general wear and tear, the harness will need to be inspected at a professional certified repair facility. Safety comes first!



The self-locking carabiners are NEVER to be used for any activities other than paragliding.

Independently from the pre-flight procedure, deploy and vent your reserve parachute on the ground before repacking it. The procedure must be done at least once a year.

Repairs

In spite of using the highest quality products used for manufacturing, it is possible for your harness to deteriorate through general use. If showing any sign of wear and tear it should be sent for inspection and/or repairs at a professional certified facility.



SUP'AIR offers an extended warranty period reaching beyond the product standard protection plan against manufacturing defects. Contact us either by telephone or by E-mail sav@supair.com to receive a quotation.

Hardware & Parts

- Self-locking Zicral 45mm carabiners. (Ref.: MAILCOMOUS).
- Reserve parachute handle (Ref. : POIB).
- Wooden seat plate (Ref. : MPPL016 to MPPL020 according to your harness size).
- Mini bump (Ref. : PROMINIBUMP).

Materials

Fabrics

CORDURA®

Polyamide 210D RIPSTOP

Straps

Polyester 28mm and 43mm (500 daN)

Polyamide 15 mm, 20 mm, 25mm et 40mm (1250 daN)

Recycling

We have minimized our manufacturing footprint by carefully selecting environmentally friendly materials; most of our components are recyclable.

If you estimate that your ACCESS AIRBAG has reached the end of its life-span, you can separate plastics from metals and dispose of them according to your community recycling rules. As for the fabric itself contact your local authorities to find out how to proceed to discard it.

SUP'AIR takes the greatest care in its products design and manufacturing and hence offers a five (5) year limited warranty from the date of purchase against manufacturing defects or flaws occurring during normal use. Any damage or degradation resulting from incorrect or abusive use, abnormal exposure to aggressive factors, including, but not limited to; high temperature, intense sun exposure, high humidity, excessive abrasion, etc, will invalidate this warranty.

Disclaimer



Paragliding is an activity requiring specific skills and sound judgement. Learn how to fly within the environment of a certified paragliding school. Carry an insurance policy with you in addition to you pilot certification. Always mind and gauge your personal skills against the weather conditions of the day. Better be safe than sorry ! SUP'AIR can not be held responsible for your paragliding decisions or activities.



This SUP'AIR product has been designed exclusively for paragliding. Any other activity such as skydiving or BASE jumping is absolutely forbidden.

Pilot's gear.



It is essential for you to wear a suitable head protection (certified paragliding helmet), adequate footwear and right clothing for the activity. Moreover carrying a reserve parachute connected to your harness in flight is highly recommend.

This page will help you keep record of your ACCESS AIRBAG scheduled maintenance.

Purchase date	
Owner's name	
Name and stamp of the shop	

<input type="checkbox"/> Care <input type="checkbox"/> Resale	
Purchase date	
Workshop's name/ Buyer's name	

<input type="checkbox"/> Care <input type="checkbox"/> Resale	
Purchase date	
Workshop's name/ Buyer's name	

<input type="checkbox"/> Care <input type="checkbox"/> Resale	
Purchase date	
Workshop's name/ Buyer's name	

<input type="checkbox"/> Care <input type="checkbox"/> Resale	
Purchase date	
Workshop's name/ Buyer's name	



SUPAIR-VLD
Parc Altaïs
34 rue Adrastée
74650 Chavanod, Annecy
FRANCE

info@supair.com
+33(0)4 50 45 75 29

45°54.024'N / 06°04.725'E