

Harness inspection certificate

Inspection certificate number: PH_260.2019

Impact pad number: PH_260.2019

Manufacturer data

Manufacturer name: **Supair Sàrl**
 Representative: **Laurent Chiabaut**
 Street: **34, rue Adrastée**
 Post code / place: **74650 Chavanod**
 Country: **France**

Sample data:

Harness

Impact pad

Name:	Altirando Lite	Name Impact pad: ⁽¹⁾	n/a
Type:	ABS	Impact pad integrated: ⁽¹⁾	Yes
Size:	L	Impact pad type:	Airbag
Weight of Sample [kg]:	2.924	Weight of Sample [kg]: ⁽¹⁾	n/a
Serial number:	ATL_L_VS.1	Serial number: ⁽¹⁾	n/a
Clip-in weight [kg]:	120	Date of reception:	19.02.2019
Integrated container for rescue system:	Yes		
Volume container [cm ³]:			
			7000 max
			3000 min
Date of reception:	19.02.2019		

Test report summary

Structual test

Impact pad test

Result	POSITIVE	POSITIVE
Place	Villeneuve	Villeneuve
Date	07.03.2019	07.03.2019

Issue data

Place of declaration: **Villeneuve**
 Date of issue: **13.05.2019**
 Managing Director: **Alain Zoller**
 Signature: 

This signature approve the validity of the test reports if available; no. 94.21 (test id R0,R2,R6,R8,R9,R10,RRDT,RRST) and no. 94.22 (test id: P1,P2,PR1,PR2)

Air Turquoise SA, having thoroughly assessed the sample mentioned above, declare it was found conform with all requirements defined by the following norms:

European Standard **EN1651 :1999**, and **EN12491:2015 chapter 5.3.2 - Airworthiness Requirements LTF nFL II 91/09 chapter 4.2.1, 5, 6.1.5 and 6.1.8**

⁽¹⁾ If Impact pad is NOT integrated in the harness, it will have independently Inspection number, and serial number. Definition of integrated impact pad is impact pad which can not be dismantled from the harness, e.g. airbag.

Present declaration's scope only extends to the conformity of a given sample, on a given date and in a given place – as mentioned here above.

This inspection certificate contain the following test and is complet with the test, if available, report: 94.21 and 94.22

Harness Impact Pad Report

Inspection certificate number: **PH_260.2019**

Manufacturer data:

Manufacturer name: **Supair Sàrl**
 Representative: **Laurent Chiabaut**
 Street: **34, rue Adrastée**
 Post code place: **74650 Chavanod**
 Country: **France**

Harness model: **Alirando Lite**

Sample data:

Name impact pad: **n/a**
 Impact pad integrated: **Yes**
 Impact pad type: **Airbag**
 Serial number: **n/a**
 Weight of sample [kg]: **n/a**
 Date of test: **07.03.2019**

Atmosphere AGL:

[C°]	20.9
RH [%]	32
[hPa]	963.3

Summary of Impact pad test ⁽¹⁾

Test id		Test configuration ⁽²⁾	Max Peak of Impact [g] ⁽³⁾	Duration at 38 [g] in [ms] ⁽⁴⁾	Duration at 20 [g] in [ms] ⁽⁵⁾	Diff. of test 1 and 2 [%] ⁽⁶⁾	Result
P	V	Test sample attached to dummy in flying position, without emergency parachute	24.37	0.00	11.67	-16.74	POSITIVE
PR	V	Test sample attached to dummy in flying position, Include emergency parachute	24.05	0.00	6.67	1.53	POSITIVE

Manufacture	Instrument	Type no	S/N	Validity Calibration
Burster/MTS	Accelerometer 100 g	89010-100	1263567	04.08.2020
JDC elec	Geos n°11 Skywatch	Geos n°11	22	08.05.2019

The validation of this test report is given by the signature of the test manager on the Inspection Certificate no 94.20

⁽¹⁾ Calculated value in tests reports include the value minus the uncertainty (on safe side) / The uncertainty stated is the expanded uncertainty obtained by multiplying the standard uncertainty by the coverage factor k = 2. The value of the measurand lies within the assigned range of values with a probability of 95%.

⁽²⁾ The dummy is lifted minimum up to 1.65 m, and impact pad is mounted on. Where the impact occurs, measure distance from bottom of impact pad to ground.

⁽³⁾ Maximum peak of impact should be less or equal to 50 [g], ⁽⁴⁾ If any, the maximum duration in at 38 [g] should be less or equal to 7 [ms], ⁽⁵⁾ If any, the maximum duration in at 20 [g] should be less or equal to 25 [ms], ⁽⁶⁾ The test should be done twice, and the 2nd test the maximum peak should not differ more than 20% from the first test, maximum peak.

This declaration must not be reproduced in part without the written permission of AIR TURQUOISE SA.

Inspection certificate number: **PH_260.2019**

Name impact pad: **n/a**

Test results of Impact pad test

	without emergency parachute		include emergency parachute	
	P1	P2	PR1	PR2
Maximum Peak of impact [g]	24.37	20.29	22.52	24.05
Impact duration at +38 [g] in [ms]	0.00	0.00	0.00	0.00
Impact duration at +20 [g] in [ms]	11.67	0.00	5.00	6.67
Uncertainty k=2[g]	1.43	1.19	1.32	1.41
Difference of test 1 and 2 [%]	100.00	83.26	100.00	106.79

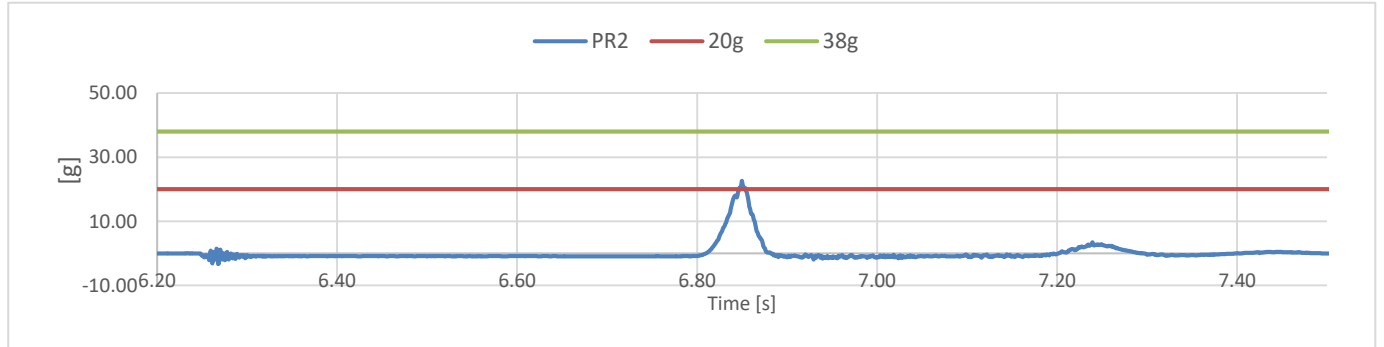
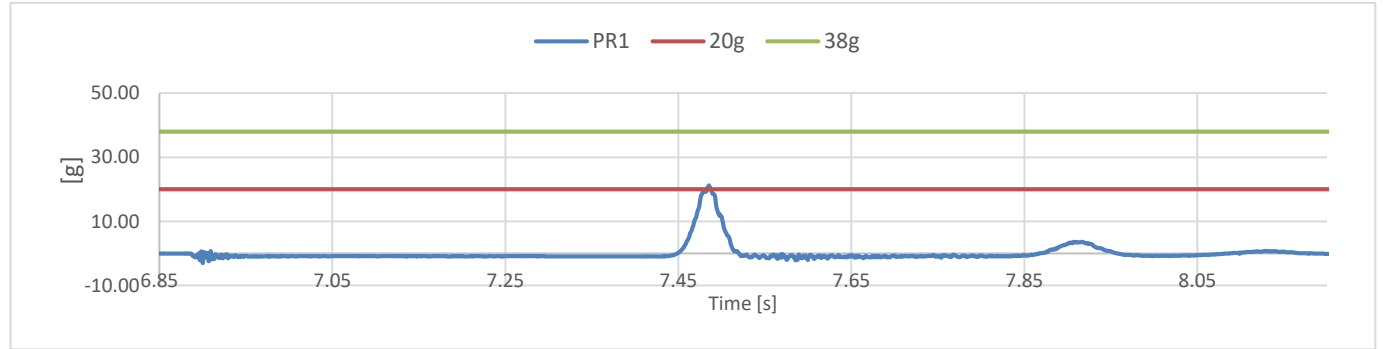
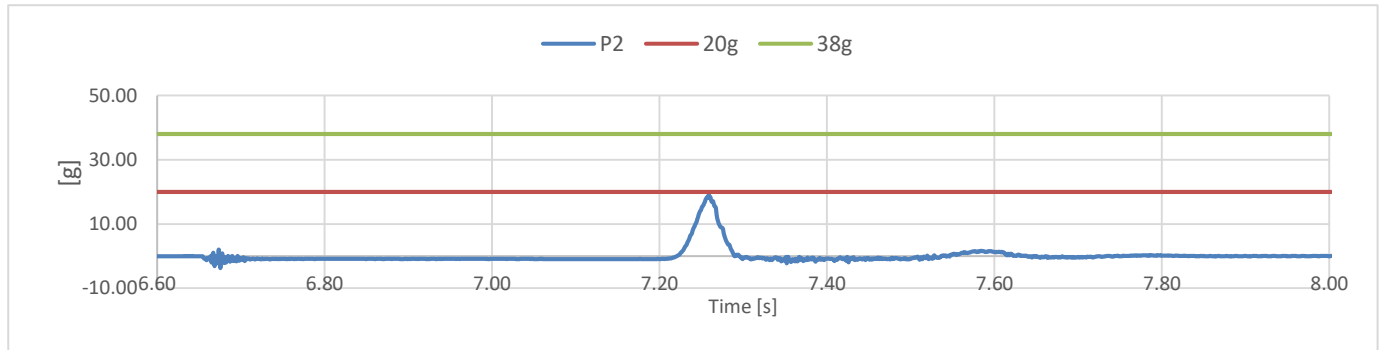
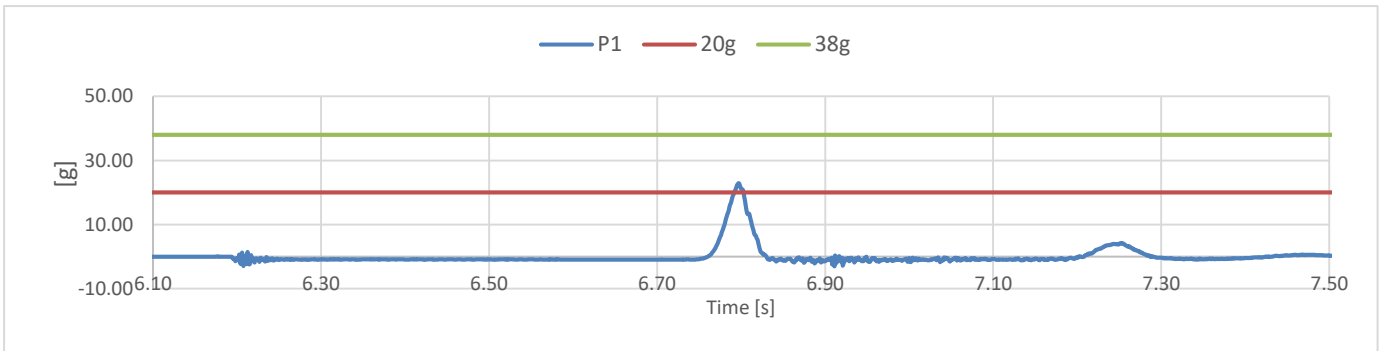

AIR TURQUOISE SA | PARA-TEST.COM
Route du Pré-au-Comte 8 • CH-1844 Villeneuve • +41 (0)21 965 65 65

Test laboratory for paragliders, paraglider harnesses
and paraglider reserve parachutes



Paragliding Harness

Inspection number : **PH_260.2019**
Manufacturer : **Supair Sàrl**
Model and size : **Altirando Lite L**
Maximum pilot weight [kg] : **120**
Integrated container for rescue system: **Yes**
If Yes. Volume of the container [cm³] : **3000 min 7000 max**
Serial number: _____
Production date (year / month) : _____

Harness protector (impact pad)

Impact pad type: **Airbag**
Impact pad integrated: **Yes**
Impact pad number: **PH_260.2019**
If not integrated : Manufacturer Serial number:
Production date (year / month) : _____

Warning : Read the operating manual before using this equipment!

A sample has been tested and certifies its conformity with the following standard: **EN1651:1999, EN12491:2015 and LTF NfL II 91/09 chapter 4 and 6**. This model corresponds with the tested sample and its airworthiness.

RE | rev 01 | 09.03.2018 | ISO 94.20

Harness Structural test Report

Inspection certificate number: **PH_260.2019**

Manufacturer data:

Manufacturer name: **Supair Sàrl**
 Representative: **Laurent Chiabaut**
 Street: **34, rue Adrastée**
 Post code place: **74650 Chavanod**
 Country: **France**

Sample data:

Name: **Altirando Lite**
 Type: **ABS**
 Size: **L**
 Serial number: **ATL_L_VS.1**
 Impact pad type: ⁽¹⁾ **Airbag**
 Clip-in weight [kg]: **120**

Date of test: **07.03.2019**

Atmosphere AGL:

[C°]	24.1
RH [%]	31
[hPa]	977.3

Summary of Structural test

Test id	- EN 1651	Setup	Req. Load [g]	Req. Load [N]	Min. duration [s]	Result
R0	✓ 5.3.2.1	Default flying position	6	7200	10	POSITIVE
R2	✓ 5.3.2.2	Default flying position	15	18000	5	POSITIVE
R4	✓ 5.3.2.7	Flying position before landing	15	18000	5	POSITIVE
R6	✓ 5.3.2.4	Rescue attachments	15	18000	5	POSITIVE
R8	✓ 5.3.2.3	Asymmetric, one riser	6	7200	10	POSITIVE
R9	5.3.2.5	Towing	5	6000	10	n/a
R10	✓ 5.3.2.6	Asymmetric, negative	4.5	5400	10	POSITIVE

Rescue deployment test

Test id	- NfL II 91/09	Setup	Min load [N]	Max. load [N]	Measured [N]	Result
RRDT	✓ 6.1.5	Default flying position	20	70	54.67	POSITIVE

Rescue Deployment Handle strength test

Test id	- EN 12491	Setup	Req. Load [N]	Min. duration [s]	Breaking strength [N]	Result
RRST	✓ 5.3.2	Two end points of handle	700	10	1261.38	POSITIVE

Manufacture	Instrument	Type no	S/N	Validity Calibration
HBM	Load Sensor GE01	1-S9M/50KN-1	31314643	14.10.2019
Burster	Sensor Burster	8431-10000	1185483	01.06.2020
JDC elec	Geos n°11 Skywatch	Geos n°11	22	08.05.2019

The validation of this test report is given by the signature of the test manager on the Inspection Certificate no 94.20

⁽¹⁾ If Impact pad available, see test report no. 94.22 and inspection certificate no. 94.20

Calculated value in tests reports include the value minus the uncertainty (on safe side) / The uncertainty stated is the expanded uncertainty obtained by multiplying the standard uncertainty by the coverage factor k = 2. The value of the measurand lies within the assigned range of values with a probability of 95%.

This declaration must not be reproduced in part without the written permission of AIR TURQUOISE SA.

Inspection certificate number: **PH_260.2019**

model: **Altirando Lite L**

Harness Structural test

Test ID R0

Standard	EN 1651:1999	120
Reference in standard	5.3.2.1	
Test setup	Default flying position	
Attachment points	Both main riser attachment (3,4)	
Anchor points	Dummy (B1, B2)	
Required load [g]	6	
Required load [N]	7200	
Minimum test duration [s]	10	
Result		
Test duration [s]	15.1	
Any signs of structural failure	No	
Test results	POSITIVE	

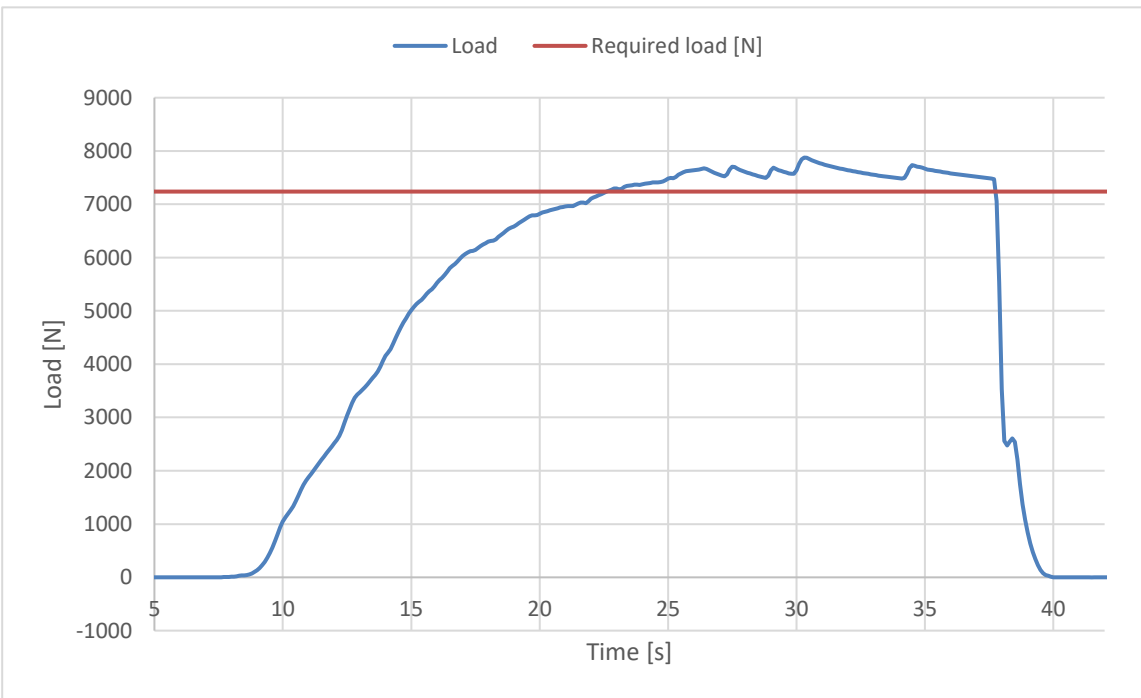
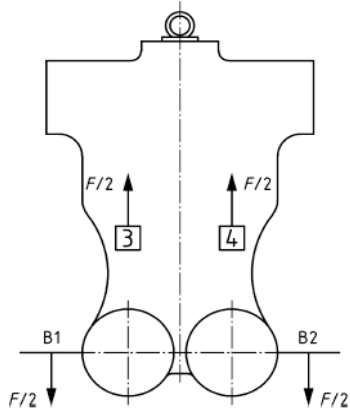

The validation of this test report is given by the signature of the test manager on the Inspection Certificate no 94.20

Inspection certificate number: **PH_260.2019**

model: **Altirando Lite L**

Harness Structural test

Test ID R2

Standard	EN 1651:1999
Reference in standard	5.3.2.2
Test setup	Default flying position
Attachment points	Both main riser attachment (3,4)
Anchor points	Dummy (B1, B2)
Required load [g]	15
Required load [N]	18000
Minimum test duration [s]	5
Result	
Test duration [s]	7.5
Any signs of structural failure	No
Test results	POSITIVE

120

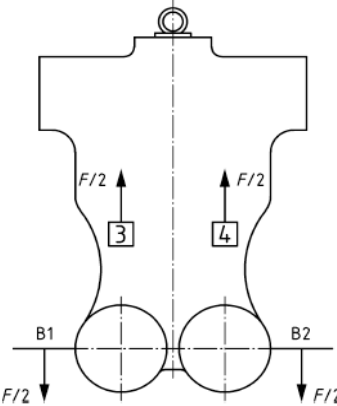
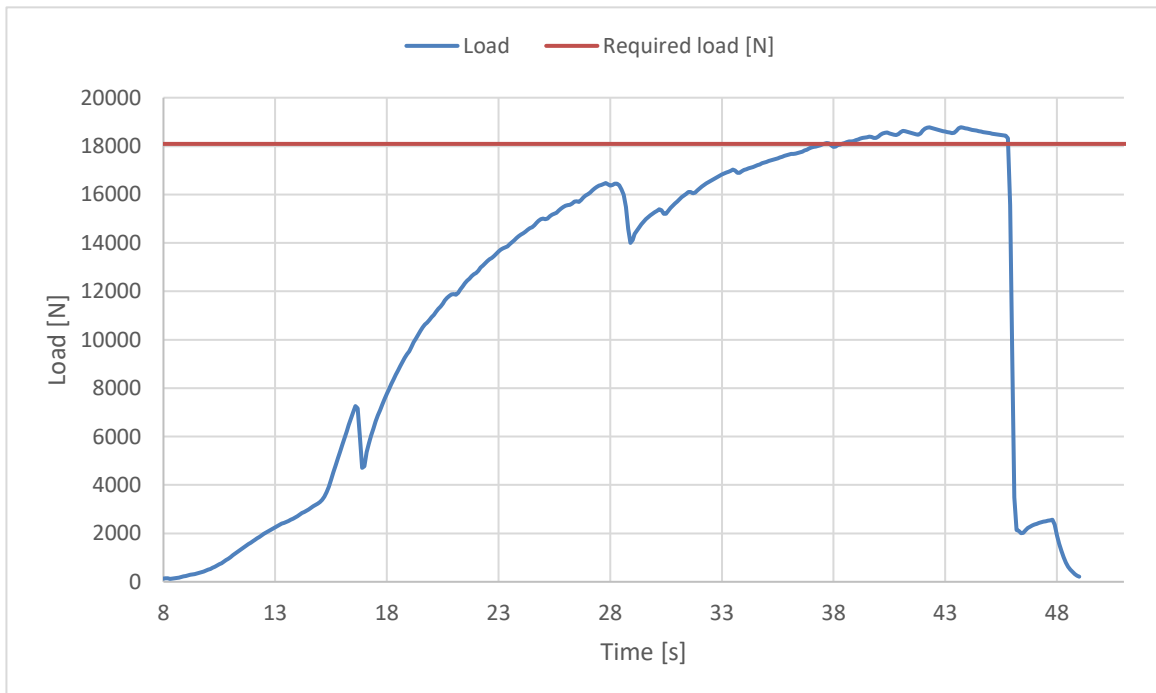
The validation of this test report is given by the signature of the test manager on the Inspection Certificate no 94.20

Inspection certificate number: **PH_260.2019**

model: **Altirando Lite L**

Harness Structural test

Test ID R4

Standard	EN 1651:1999
Reference in standard	5.3.2.7
Test setup	Flying position before landing
Attachment points	Both main riser attachment (3,4)
Anchor points	Dummy (7,8)
Required load [g]	15
Required load [N]	18000
Minimum test duration [s]	5
Result	
Test duration [s]	10.9
Any signs of structural failure	No
Test results	POSITIVE

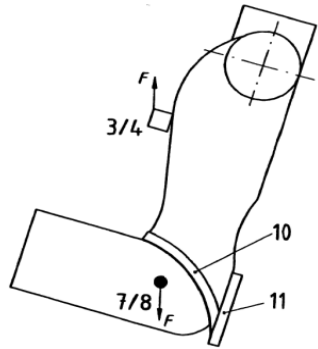

120

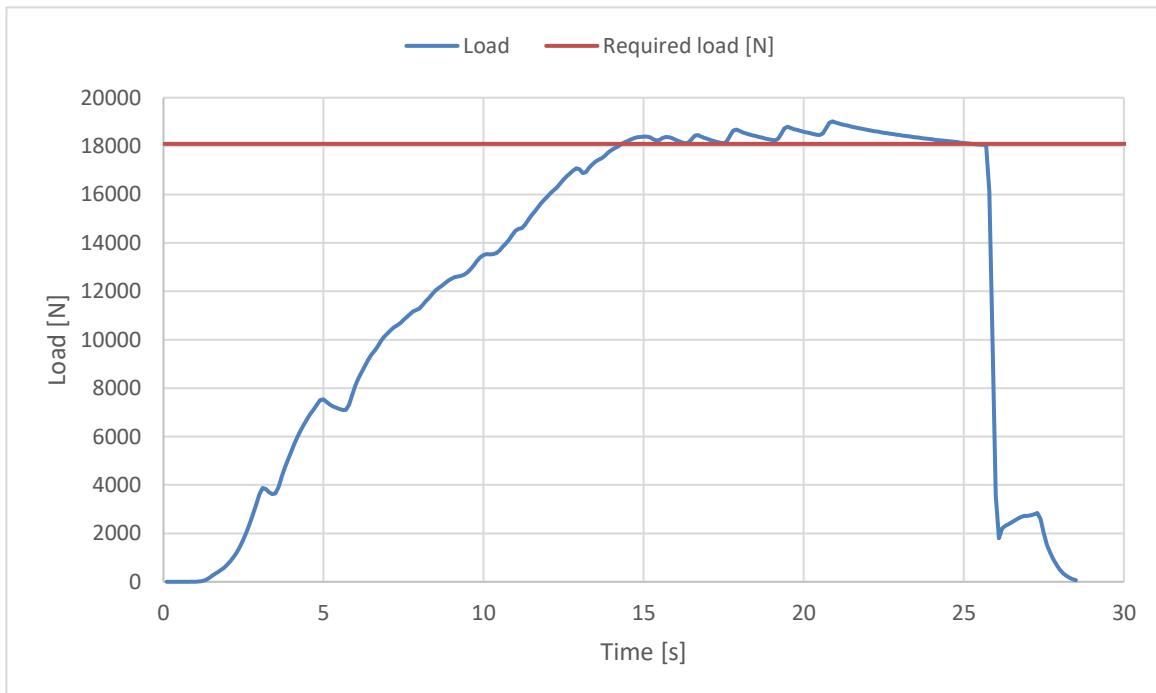

The validation of this test report is given by the signature of the test manager on the Inspection Certificate no 94.20

Inspection certificate number: **PH_260.2019**

model: **Altirando Lite L**

Harness Structural test

Test ID R6

Standard	EN 1651:1999
Reference in standard	5.3.2.4
Test setup	Rescue attachments
Attachment points	Rescue riser attachment (1,2)
Anchor points	Dummy (B1,B2)
Required load [g]	15
Required load [N]	18000
Minimum test duration [s]	5
Result	
Test duration [s]	7.5
Any signs of structural failure	No
Test results	POSITIVE

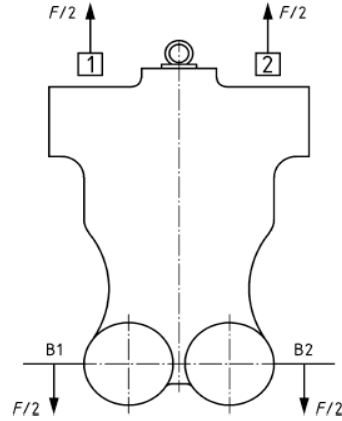

120

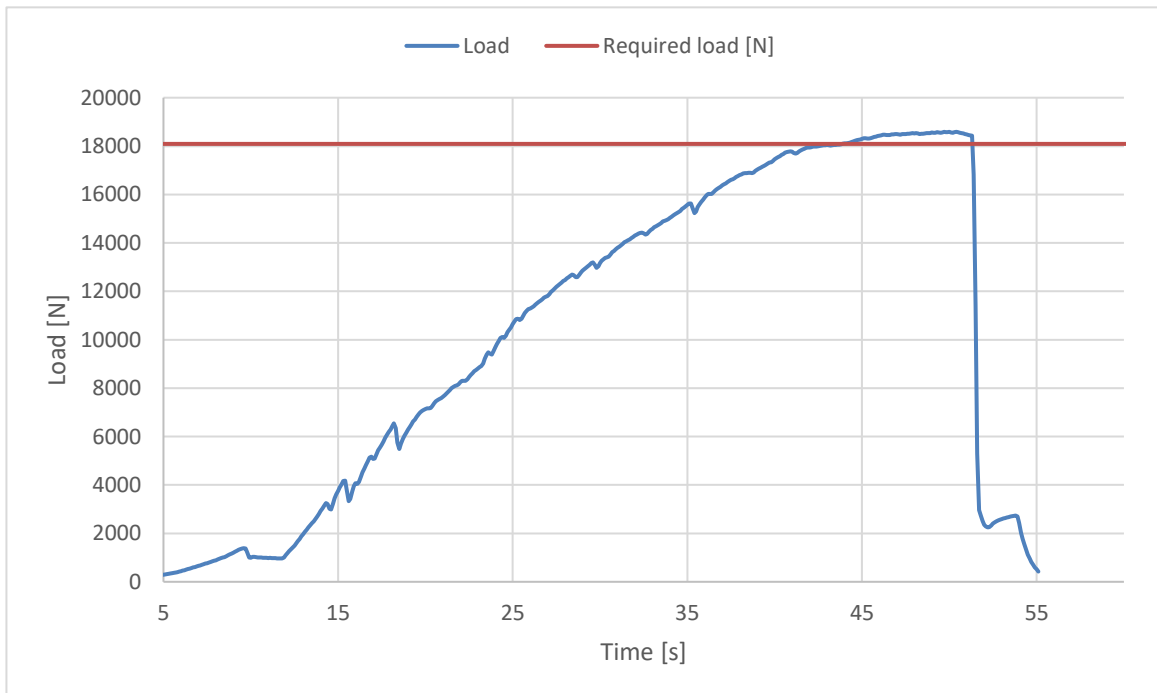

The validation of this test report is given by the signature of the test manager on the Inspection Certificate no 94.20

Inspection certificate number: **PH_260.2019**

model: **Altirando Lite L**

Harness Structural test

Test ID R8

Standard	EN 1651:1999
Reference in standard	5.3.2.3
Test setup	Asymmetric, one riser
Attachment points	One main riser attachment (3)
Anchor points	Dummy (B1,B2)
Required load [g]	6
Required load [N]	7200
Minimum test duration [s]	10
Result	
Test duration [s]	14
Any signs of structural failure	No
Test results	POSITIVE

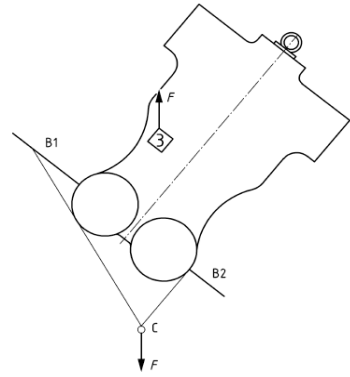

120

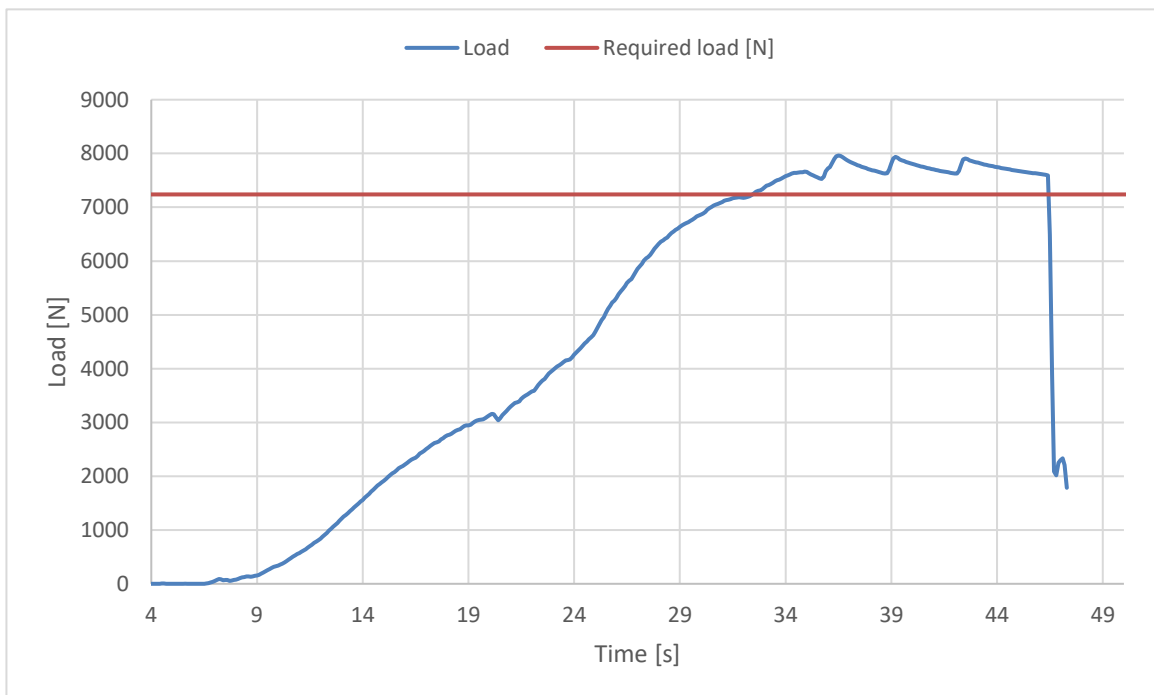

The validation of this test report is given by the signature of the test manager on the Inspection Certificate no 94.20

Inspection certificate number: **PH_260.2019**

model: **Altirando Lite L**

Harness Structural test

Test ID R10

Standard	EN 1651:1999	120
Reference in standard	5.3.2.6	
Test setup	Asymmetric, negative	
Attachment points	One main riser attachment (3 or 4) downwards	
Anchor points	Dummy (9)	
Required load [g]	4.5	
Required load [N]	5400	
Minimum test duration [s]	10	
Result		
Test duration [s]	17	
Any signs of structural failure	No	
Test results	POSITIVE	

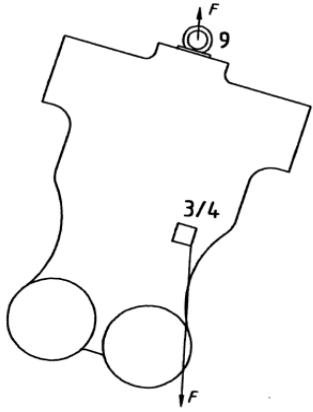
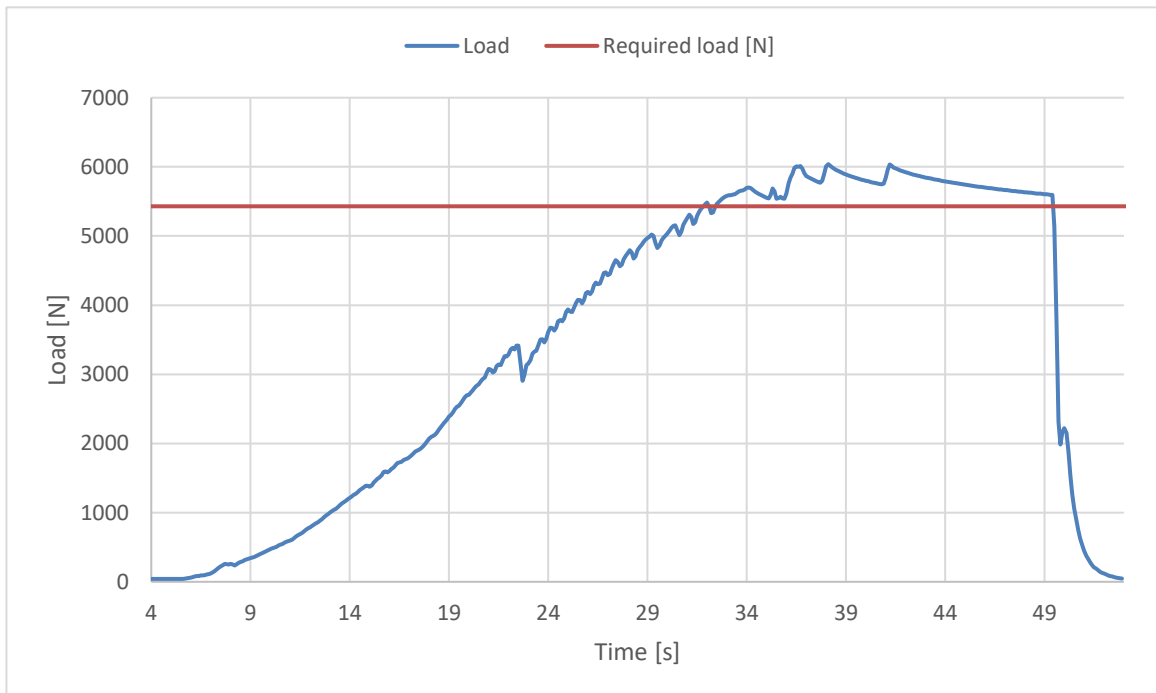
The validation of this test report is given by the signature of the test manager on the Inspection Certificate no 94.20

Inspection certificate number: **PH_260.2019**

model: **Altirando Lite L**

Rescue Deployment Test

Test ID RRDT

Standard	LTF NfL II 91/09
Reference in standard	6.1.5
Test setup	Default flying position
Attachment points	Sensor connect to handle, and pull in opening direction
	The test is to simulate the load required to open the emergency parachute(1st action).
Min. Required load [N]	20
Max. Required load [N]	70
Result	
Load for first action [N]	54.67
Test results	POSITIVE

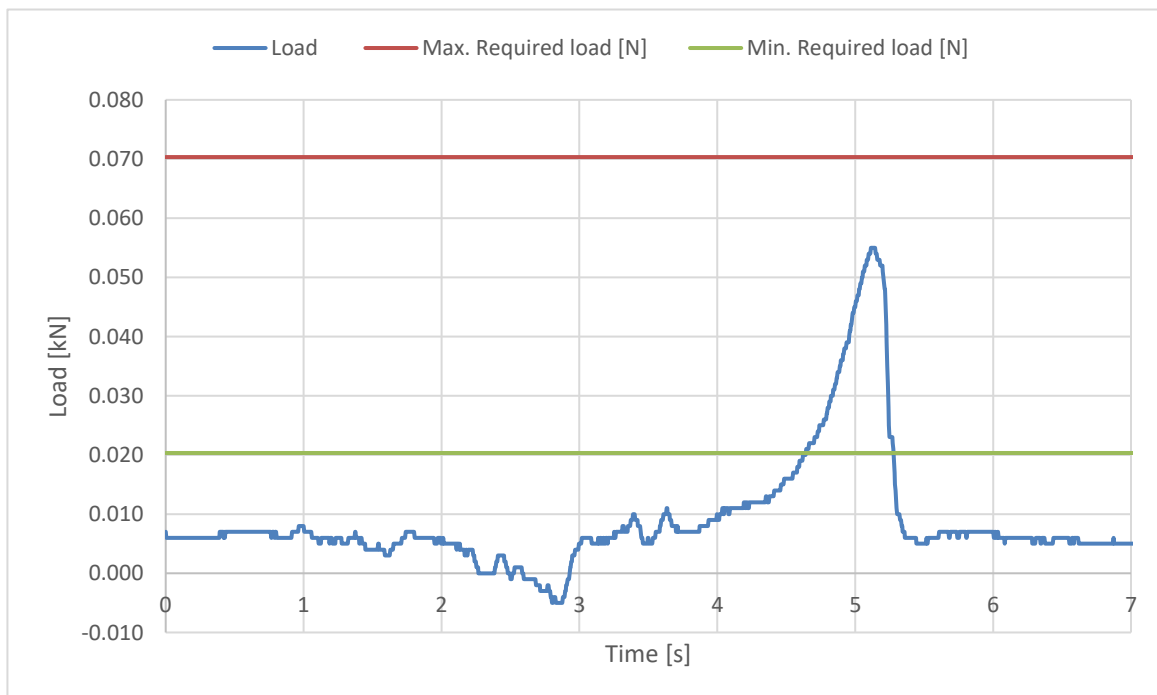

The validation of this test report is given by the signature of the test manager on the Inspection Certificate no 94.20

Inspection certificate number: **PH_260.2019**

model: **Altirando Lite L**

Rescue Deployment Handle strength test

Test ID RRST

Standard	EN12491:2015
Reference in standard	5.3.2
Test setup	Two end points of handle
Attachment points	Sensor connect to end of handle, pull on the other side
	The handle must support min 700 N for 10 s, after measure breaking strength
Min. Required load [N]	700
Minimum test duration [s]	10
Result	
Test duration [s]:	13.6
Breaking strength [N]	1261.38
Test results	POSITIVE

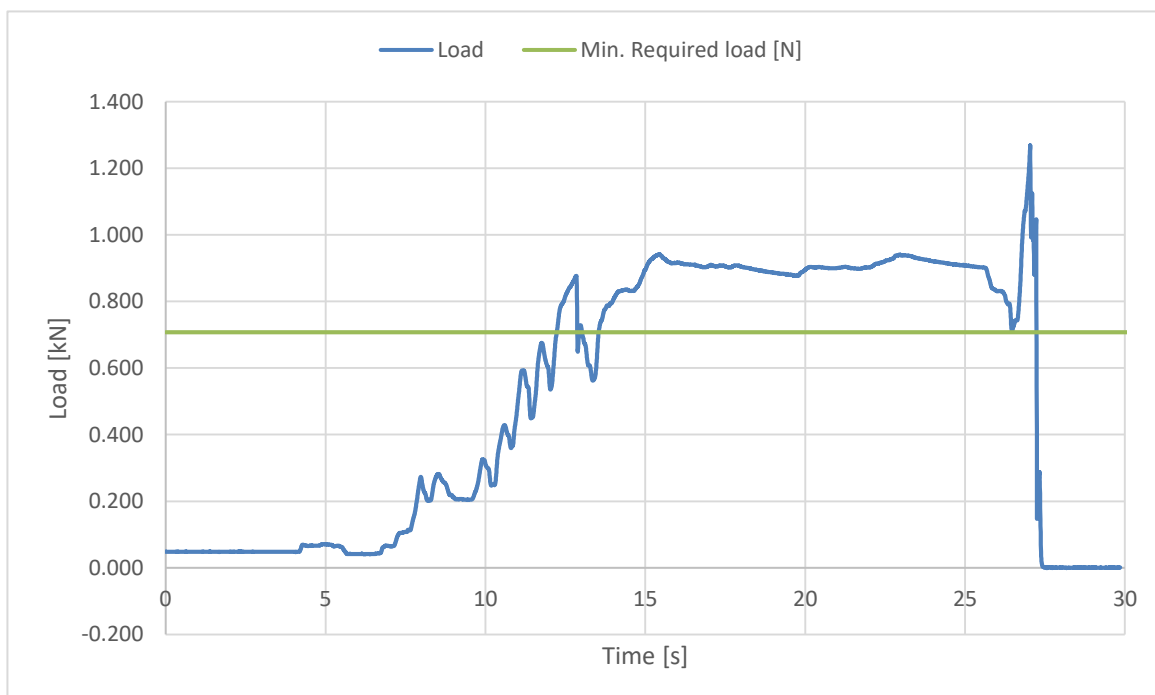

The validation of this test report is given by the signature of the test manager on the Inspection Certificate no 94.20